

PPI

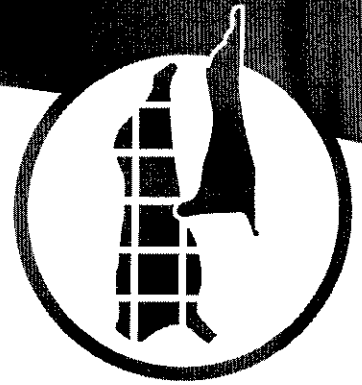

Noise control for abattoirs M.338E

1995

Prepared by:
**David Caple &
Associates**

ISBN: 1 74036 930 0
Published: June 1995
© 1998

This publication is published by Meat & Livestock Australia Limited ABN 39 081 678 364 (MLA). Where possible, care is taken to ensure the accuracy of information in the publication. Reproduction in whole or in part of this publication is prohibited without the prior written consent of MLA.



MEAT & LIVESTOCK
A U S T R A L I A

CONTENTS:

Introduction	1
About This Booklet	1
What Noise Levels are Acceptable?	2
Do We Have A Problem?	2
Definitions	3
Examples Of Successful Noise Control Strategies	4
N01 Prebreaker and breaker machines	5
N02 Impact noise in Boning Room	6
N03 Chiller fans	7
N04 Chain noise	8
N05 Air noise from chain cleaners	9
N06 Air knives	10
N07 Trap doors	11
N08 Hide pullers	12
N09 Knocking guns	13
N10 Knocking boxes	14
N11 Guards	15
N12 Vacuuming machines	16
N13 Plant Equipment	17
N14 Hook handling	18
N15 Hook cleaning	19
N16 Air-conditioning	20
N17 Engine transmission noise	21
N18 Tapping on handrails	22
N19 New equipment	23
Principles of Noise Control	24
Noise Control Planning	25
Engineering Controls	25
At the Source	26
Via the transmission path	26
Prioritizing Engineering Based Noise Controls	27
Appendices	28
a. Measuring Noise In Abattoirs	29
b. Administrative Controls	30
c. Personal Protective Equipment	31
d. How We Hear	34
e. Definitions	36
f. Useful contacts	39
g. Useful References	40

INTRODUCTION

Work related Noise Induced Hearing Loss (NIHL) is the most prevalent compensable industrial disease in industry in Australia and entails substantial economic costs (preface to National Standard 1993).

In addition to compensation costs, exposure to noise also entails largely unquantifiable costs to organizations by way of increased employee turnover, absenteeism and uncalculatable social impact.

Traditional efforts to control NIHL have been towards the use of administrative controls (ie rotation of workers into and out of noisy areas) and the use of personal protective equipment, ie earplugs and muffs.

The emphasis of the current Regulations and Codes of Practice in Australia is towards the development of engineering controls, as the primary control priority.

ABOUT THIS BOOKLET

This booklet has been developed to assist in controlling excessive noise in abattoirs particularly through the use of engineering controls. It has been prepared for Abattoir owners, Engineers, OHS Committees and OHS Representatives as a practical guide. The suggestions listed in the second part were provided primarily by the Abattoirs participating in the O, H & S Best Practice Project; manufacturers of meat processing equipment and specialist noise control companies. A sample of 19 noise problems and 73 solution options to noise control have been provided.

The contribution of these people, especially the Abattoirs in the O, H & S Best Practice Project was greatly appreciated.

This MRC booklet for the Meat Industry is intended to:

- a. Provide practical solutions to assist in the reduction of noise levels at abattoirs using engineering control methods.
- b. Promote the recognition and understanding of the effects of the exposure to noise.
- c. Promote the implementation of engineering controls as a practicable method of controlling excessive noise.
- d. Promote implementation through established consultative processes.

WHAT NOISE LEVELS ARE ACCEPTABLE?

The National Standard for the exposure to noise in the occupational environment is expressed as:

1. Maximum allowable 8 hrs continuous exposure level of 85 dB(A).
2. Peak noise level should never exceed 140 dB(lin).

These levels as specified in the National Standard are the maximum acceptable exposure levels for noise in the workplace. However, over long periods, repeated noise exposure at between 75 dB(A) and 85 dB(A) may be small risks to some people. With progressively increasing levels, the risk becomes greater. Workplace noise levels lower than 85 dB(A) are therefore desirable, if practicable. (Preface to National Standard 1993).

The National Code of Practice for Noise Management and Protection at Work, (NOHSC : 2009 (1993)) provides practical guidance on how the National Standard for Occupational Noise can be achieved. This Code of Practice should be consulted when addressing the issue of noise, as it applies to all workplaces where there is a potential for exposure to excessive noise. It provides a framework for the management of exposure to noise at work and for minimizing the risks of the effects of such exposure.

DO WE HAVE A PROBLEM ?

Our research shows that in general a high proportion of work areas in abattoirs have noise levels in excess of 85 dB(A). The highest levels (peak) were due to metal contact, ie 111 dB(A), from dropping metal hooks and rollers into metal bins, and in the knocking areas where peak levels were in excess of 140 dB(lin) and typical Leq values were around 96 dB(A). Animal noise from pigs prior to slaughter was registered at 104 dB(A).

DEFINITIONS

Various measurement systems are used for noise assessments. A complete list of definitions from the National Code of Practice for Noise Management, and protection of hearing at work is provided in the Appendix.

Some key definitions include:

- Decibel (dB) - the measure of how much noise (or sound pressure level). It is a logarithmic scale and each increase in 3dB is equivalent to doubling the energy of the noise in an area.
- dB(A) - noise levels are commonly expressed in dB(A). The "A" weighting follows the average human hearing response and enables the intensity of noise with different frequency characteristics to be compared.
- L_{eq} - the equivalent noise level is the continuous steady state noise level which would contain the same energy as the time varying noise for hearing conservation purposes. This value is obtained over a period of 8 hours.
- L_{Aeq 8 hour} - the "A" weighted equivalent noise level measured over an 8 hour period.
- L_{Aeq (Lin)} - the peak noise level measured over a certain time period using a linear frequency response.

EXAMPLES OF SUCCESSFUL NOISE CONTROL STRATEGIES

The following pages contain a range of engineering based suggestions, which are provided as practical initiatives to common noise problems in abattoirs.

These suggestions provide details of typical noise levels taken during noise surveys, and are estimates of the $L_{Aeq\ 8\ hr}$ and $L_{peak\ (Lin)}$ values for the particular noise source. The levels given are considered typical for the type of noise source measured, but it is expected that with different machines or workplaces noise levels will vary.

Due to this and the inavailability of before and after measurements, quantification of the benefits have not been included. As the various meat works trial these suggestions, they may like to conduct before and after readings and inform the MRC to enable updating of these strategies if possible.

Initial trials suggest that reductions in noise levels of 3-6 dB(A) will commonly be found with these initiatives. The actual reduction will depend on the background noise levels within the abattoirs around the noise source.

These suggestions have been developed for domestic abattoirs, and should be checked with the relevant licencing agencies prior to installing them in Export premises in case hygiene problems may be present.

MRC - O, H & S BEST PRACTICE PROJECT
NOISE CONTROL OPTIONS No:N01

AREA:

Boning Room/Offal Rooms

NOISE SOURCE:

Prebreaker and breaker machines

$L_{Aeq\ 8\ hrs} \ 96\ dB(A)$

CONTROL OPTIONS:

1. Damping of chutes and metal casings with double skin interspersed with a heavy material (eg. concrete, sandwich, etc) or acoustic attenuating materials. e.g "noiseless" steel - a laminated material.
2. Isolate breakers from general work areas.
3. Installation of lids and flaps to reduce the speed of bone entry and block noise transmission.

Diagram of cross section of double skinned chute

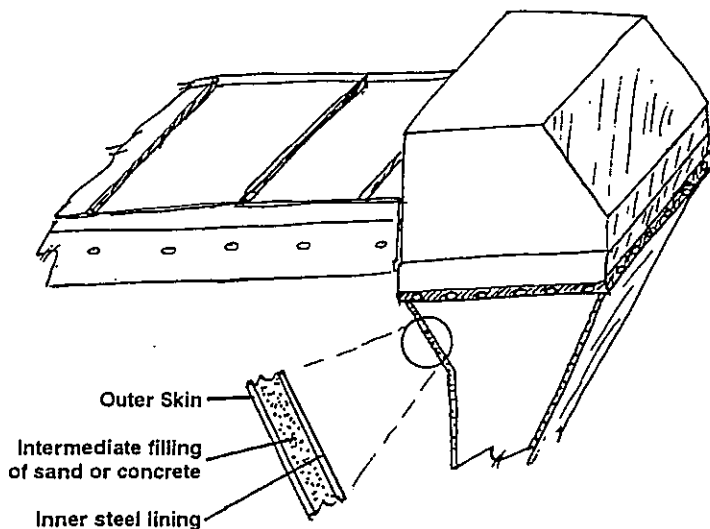

MRC - O, H & S BEST PRACTICE PROJECT
NOISE CONTROL OPTIONS No: N02

AREA:

Boning Room

NOISE SOURCE:

(1) Impact Noise - bones, meat against metal surfaces

$L_{Aeq\ 8\ hrs} .95\ dB(A)$

CONTROL OPTIONS:

1. Reduce distance between chutes and work areas, to reduce the height of the drop.
2. Dampen chutes - (see solution sheet N01 on chute design.)
3. Apply noise damping materials to the underside of the surfaces. Ensure hygiene requirements are not compromised by dampening material selected.

Diagram of metal surface with the application of noise damping materials.

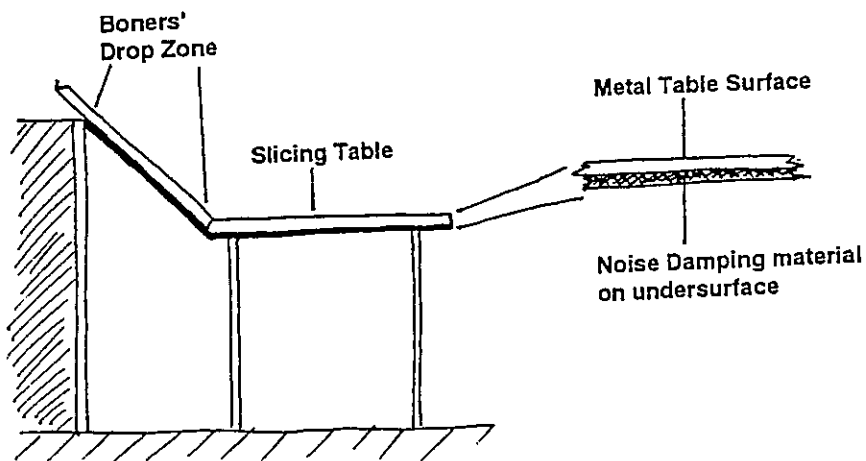

MRC - O, H & S BEST PRACTICE PROJECT
NOISE CONTROL OPTIONS No: N03

AREA:

Chillers/Freezers

NOISE SOURCE:

Overhead fans (chiller fans)

$L_{Aeq\ 8\ hr}$ 95 dB(A)

CONTROL OPTIONS:

1. Manually control or use door interlocked variable speed control units eg. when door is open fan slows to reduce noise, when door is closed high speed is engaged (use timer to re-activate high speed after nominated time to reduce chance of interlock failure).
2. Reduce fan tip speed to reduce the noise generation (in consultation with the manufacturers)
3. Use multiblade, low noise fans instead of 6 blade fans as are in the older units.
4. Run fans at lower speed during loading and high speed during chilling phase. Restrict entry during chilling.
5. Fit sound attenuators to fans.

Lower the speed of fan, lower the noise.

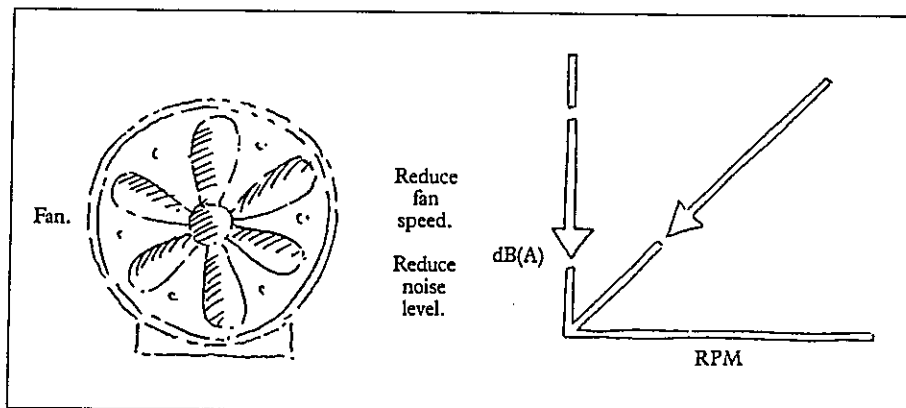

MRC - O, H & S BEST PRACTICE PROJECT
NOISE CONTROL OPTIONS No: N04

AREA:

Kill Floor

NOISE SOURCE:

- (1) Chain noise - metal on metal
- shackle noise
- conveyor changeover

$L_{Aeq\ 8\ hr}$ 94 dB(A)

CONTROL OPTIONS:

1. Nylon rollers or bushes on the contact points running on nylon coated rails
2. Redesign chain to minimize metal to metal contacts, especially where shackles, hooks and the rail impact.
eg. - smooth changeover
- lower speed of moving parts
- use nylon/rubber/plastic alternatives at impact points.

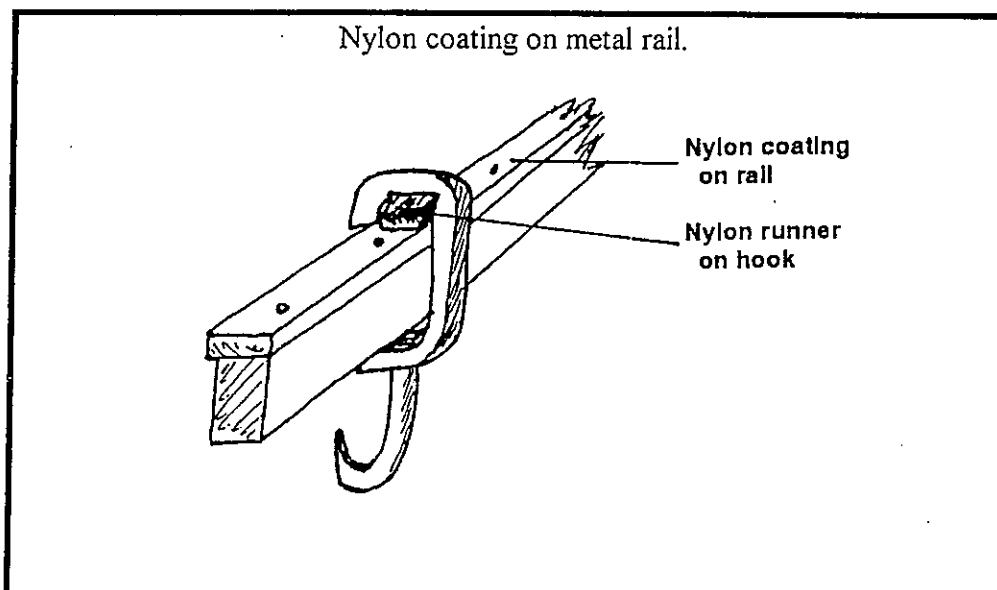

MRC - O, H & S BEST PRACTICE PROJECT
NOISE CONTROL OPTIONS No: N05

AREA:

Kill Floor

NOISE SOURCE:

Air noise from chain cleaners

CONTROL OPTIONS:

1. Modify outlets of air cleaners to low noise nozzles - not straight blow or alternatively fit mufflers to air exhausts.
2. Relocate cleaners to low employee exposure areas, and/or run only at non production times to minimize exposure.
3. Install alternative chain cleaners to pneumatic types, eg captive brushes, or use manual cleaning technology.

Low noise nozzles

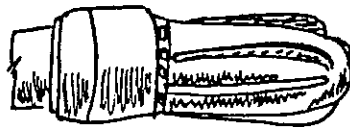

Low noise, high efficiency
air nozzles

MRC - O, H & S BEST PRACTICE PROJECT
NOISE CONTROL OPTIONS No: N06

AREA:

Kill Floor / Boning Room

NOISE SOURCE:

Air knives - speed, effectiveness of filters

$L_{Aeq\ 8\ hr}$ 95 dB(A)

CONTROL OPTIONS:

A) Exhaust air noise

- (1) Keep air pressure to manufacturers specifications
- (2) Fit air filters or mufflers to decrease exhaust noise
- (3) Pipe away exhaust air from the operators immediate area.

B) Blade Noise

- (1) Regular maintenance of blade and running housing including correct lubrication.
- (2) Lower speed of knives where possible
- (3) Test and purchase alternative designs with lower actual noise generation.

Air mufflers fitted to exhaust to decrease noise

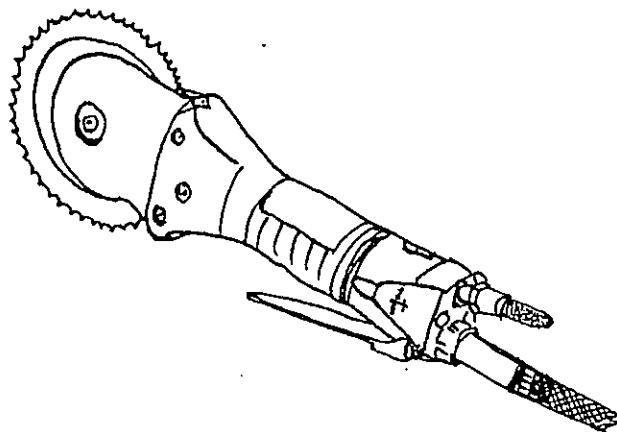

MRC - O, H & S BEST PRACTICE PROJECT
NOISE CONTROL OPTIONS No: N07

AREA:

Kill Floor / Paunch processing

NOISE SOURCE:

- (1) Impact Noise - bones, offal against metal trap doors and metal conveyors
- trap doors against chutes

$L_{Aeq\ 8\ hr}$ 90 dB(A)

CONTROL OPTIONS:

1. Removal of metal trap door and / or replace with rubber or similar material
2. Provide cushioning between metal trap door and chute
3. Damp chute (see solution N 01)
4. Use rubber conveyors instead of metal.

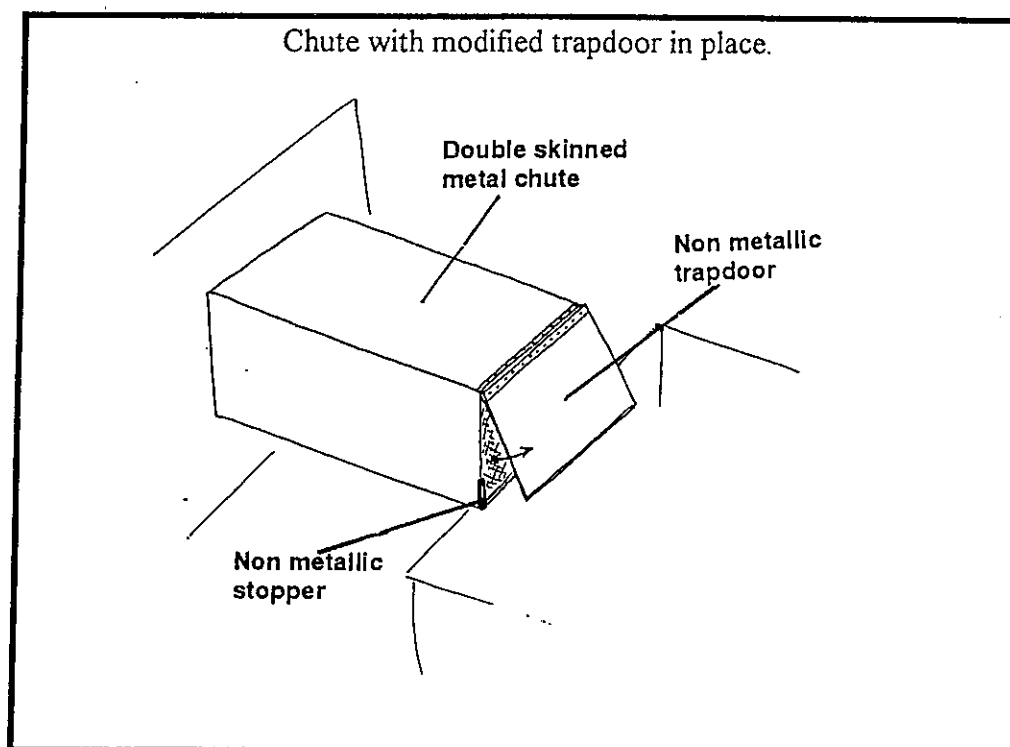

MRC - O, H & S BEST PRACTICE PROJECT
NOISE CONTROL OPTIONS No: N08

AREA:

Kill Floor

NOISE SOURCE:

Hide Pullers - metal to metal contact of chain on chute, plates and drum
- machine noise
- air noise

$L_{Aeq\ 8\ hr}\ 90\ dB(A)$

CONTROL OPTIONS:

1. Apply damping materials to rear of chutes/plates
2. Installation of alternative materials (nylon, rubber, etc) on chutes
3. Reduction in height and speed of fall of chains and hide
4. Filtered or redirected exhaust air away from the work area.
5. Apply damping material to inside of drum.
6. Purchase low noise equipment that has reduced air pressure requirements of the dehider. (Compare manufacturers and models)

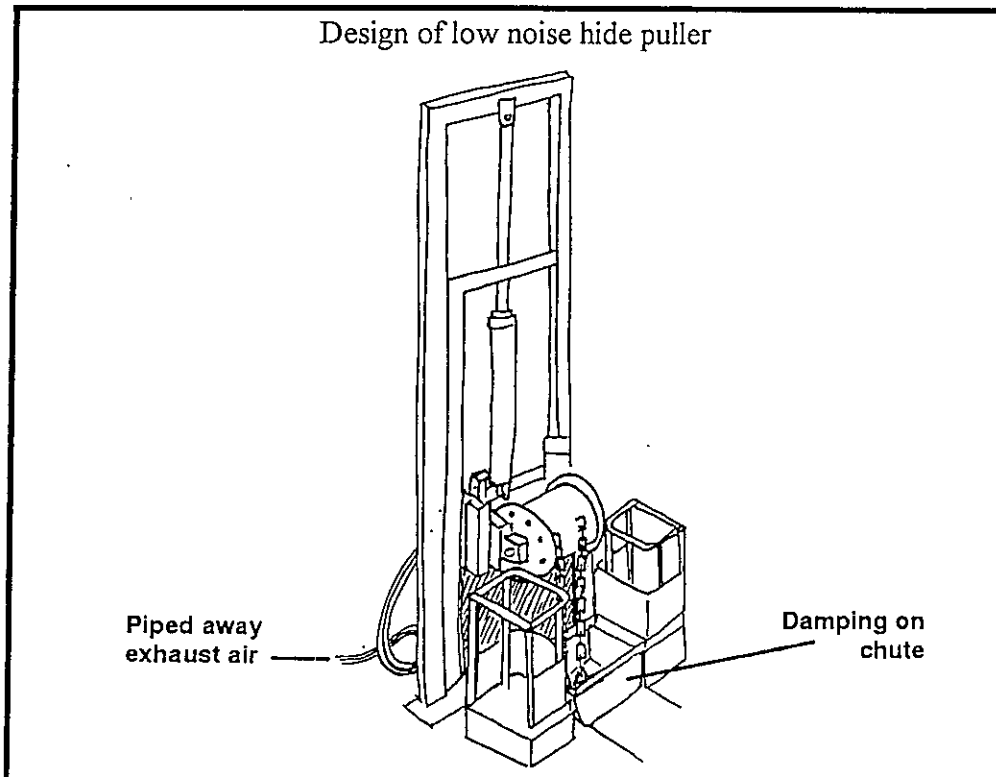

MRC - O, H & S BEST PRACTICE PROJECT
NOISE CONTROL OPTIONS No: N09

AREA:

Knocking

NOISE SOURCE:

(1) Explosive knocking system

$L_{Aeq\ 8\ hr}$ 98 dB(A)
 $L_{peak\ (lin)}$ 141 dB(lin)
 151 dB(lin) misfire

CONTROL OPTIONS:

1. Reduce impulse noise by using alternatives to traditional explosive knocking.
eg. 1.1 Electric Stun (mutton)
 1.2 CO2 bath (pigs)
 1.3 Pneumatic powered gun with piped exhaust
2. Isolate knocking area from the rest of the plant, using sound proof, i.e. concrete separation walls.

Pneumatic knocking gun for beef kill.

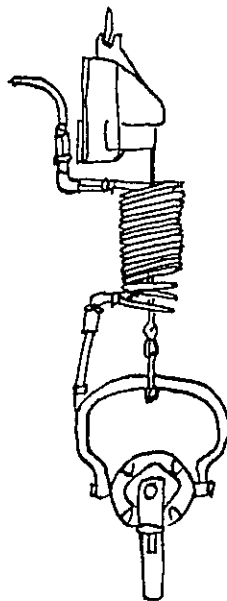

MRC - O, H & S BEST PRACTICE PROJECT
NOISE CONTROL OPTIONS No: N10

AREA:

Knocking

NOISE SOURCE:

Impact Noise - animal against knocking box
- knocking box mechanisms

CONTROL OPTIONS:

1. More rigid knocking box with solid panels to minimize vibration.
2. Secure beast to prevent thrashing about
e.g head secured, sides secured.
3. Rotating knocking box to reduce impact noise when beast falls
onto conveyer/floor.
4. Nylon guides in door mechanism to dampen the impact of the door
against the frame
5. Modification of the gate closure by either:
 - 5.1 Slowing down air cylinders towards the end of the stroke.
 - 5.2 Noise damping to stop gate closure impact noise.
 - 5.3 Stop gate short of end closure to stop end impact

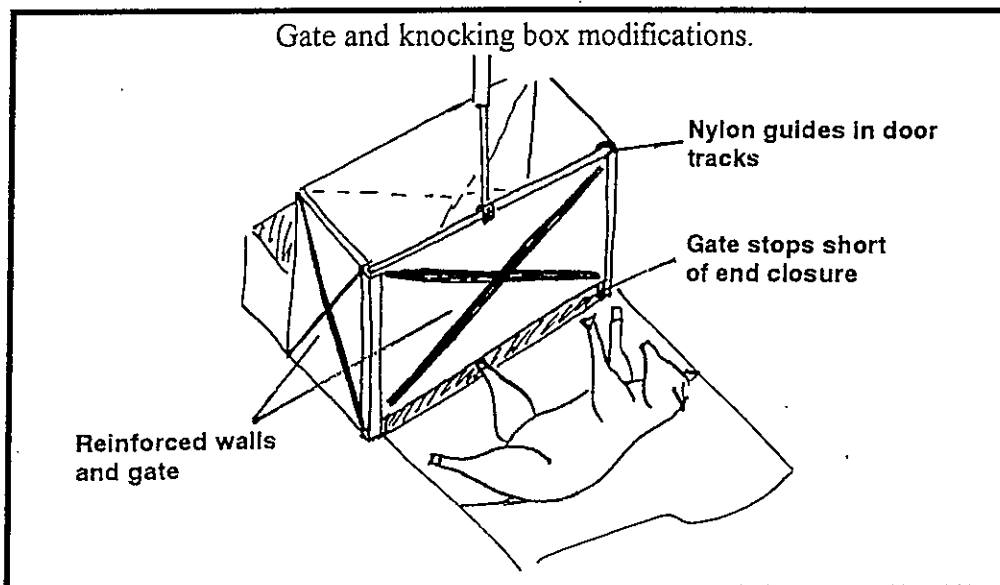

MRC - O, H & S BEST PRACTICE PROJECT
NOISE CONTROL OPTIONS No: N11

AREA:

All, especially offal.

NOISE SOURCE:

Guards on processing equipment that cover motors, belts, chains etc that vibrate.

$L_{Aeq\ 8\ hr}$ 86 dB(A)

CONTROL OPTIONS:

1. Secure guards to machine
2. Isolate guards from transmission sources
3. Replace thin sheet steel guards with heavier materials and provide damping materials on the guard.

Diagram of secured guard in place showing damping materials.

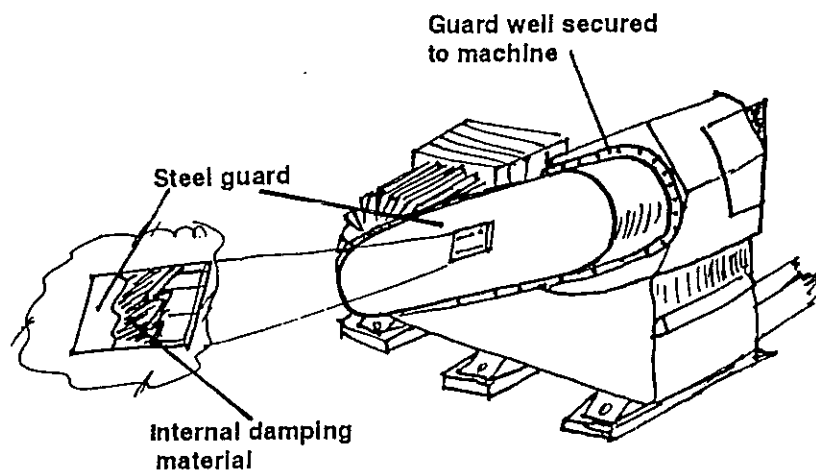

MRC - O, H & S BEST PRACTICE PROJECT
NOISE CONTROL OPTIONS No: N12

AREA:

Packing/Boning Rooms

NOISE SOURCE:

Vacuum Packing Machines - air noise

$L_{Aeq\ 8\ hr}$ 88 dB(A)

CONTROL OPTIONS:

1. Additional air filtering if possible
2. Damping the paneling of the machine to decrease transmission.
3. Remove the vacuum machine away from the packing area to reduce extent of exposure.
4. Fit low noise fittings to exhausts on the offcut blower for the rotary type vacuum machines. ("Silvent" are suitable as a retrofit for most types.)

Low noise fitting on offcut blower.

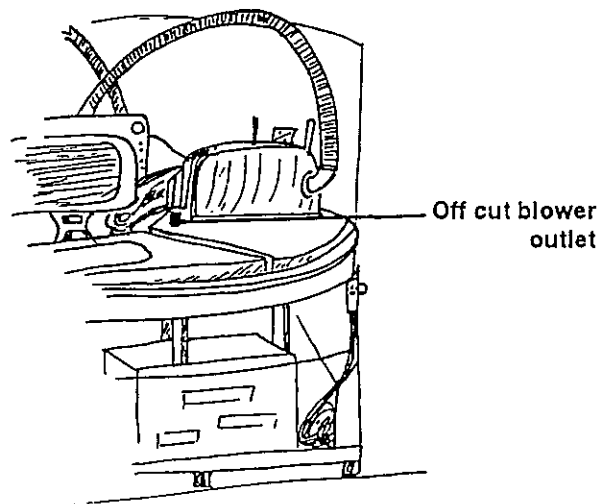

MRC - O, H & S BEST PRACTICE PROJECT

NOISE CONTROL OPTIONS No: N13

AREA:

Plant Rooms

NOISE SOURCE:

- | | | |
|-----|--------------------------|-----------------------------|
| (1) | Water pumps | $L_{Aeq\ 8\ hrs}$ 92 dB(A) |
| (2) | Air compressors/Chillers | $L_{Aeq\ 8\ hrs}$ 105 dB(A) |
| (3) | Boilers | $L_{Aeq\ 8\ hrs}$ 94 dB(A) |

CONTROL OPTIONS:

1. Separation from main employee areas
2. Enclosed in acoustic enclosures
3. Use screw compressors instead of reciprocating compressors

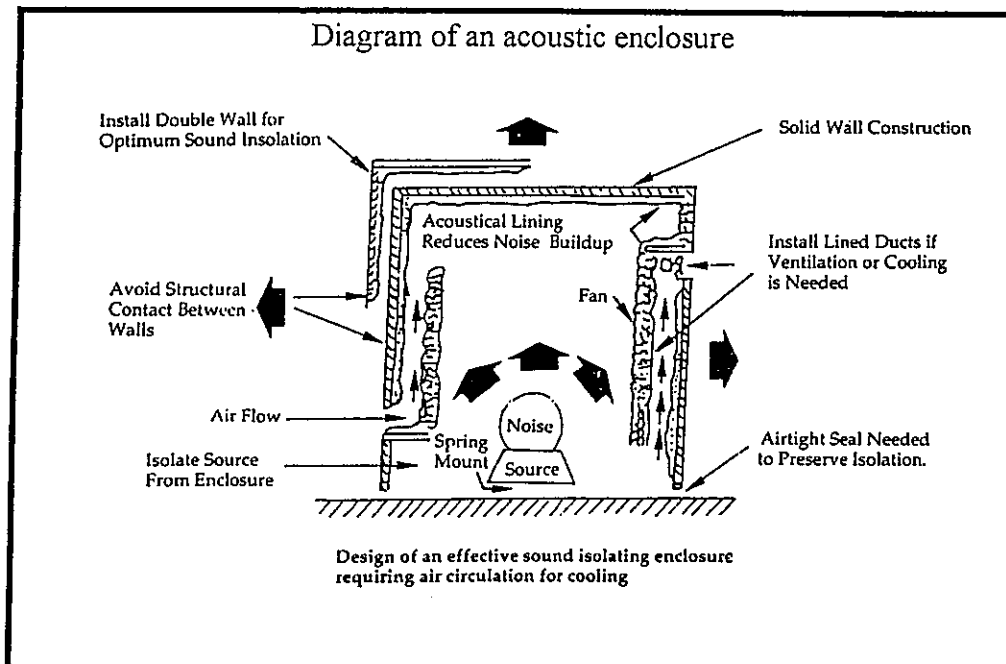

MRC - O, H & S BEST PRACTICE PROJECT
NOISE CONTROL OPTIONS No: N14

AREA:

Various - hook handling, hook return conveyors/rails

NOISE SOURCE:

Impact noise from hooks hitting each other and from metal on metal contact with metal rails

$L_{A eq 8 hr} 95 \text{ dB(A)}$

CONTROL OPTIONS:

1. Modification of roller controls to avoid hook to hook impacts
2. Slow down movement of rollers
3. Provide cushioning of mechanisms at metal to metal impact points
4. Enclose hook return conveyors

Enclose Hook return conveyors

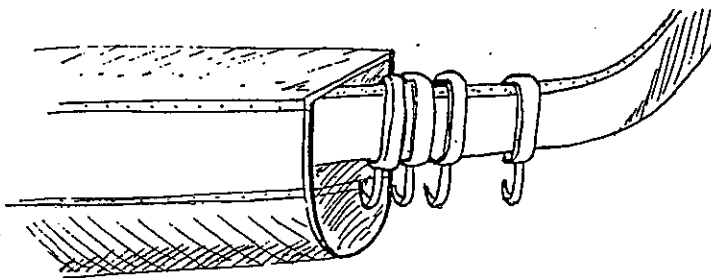

MRC - O, H & S BEST PRACTICE PROJECT
NOISE CONTROL OPTIONS . No: N15

AREA:

Various - hook cleaning

NOISE SOURCE:

Hook impact from hitting each other and from dropping into bins or crates.

$L_{Aeq\ 8\ hr}$ 95 dB(A)

CONTROL OPTIONS:

1. Reduce height of drop.
2. Modify design of bin to reduce impact and dampen noise of hooks being dropped into bin (see No.01).
3. Relocate away from main work areas
4. Use non metallic chute, conveyor to transport hooks to bin/cleaning areas.
5. Slow down speed of hook return by reducing the gradient and height of the fall of the return rail.

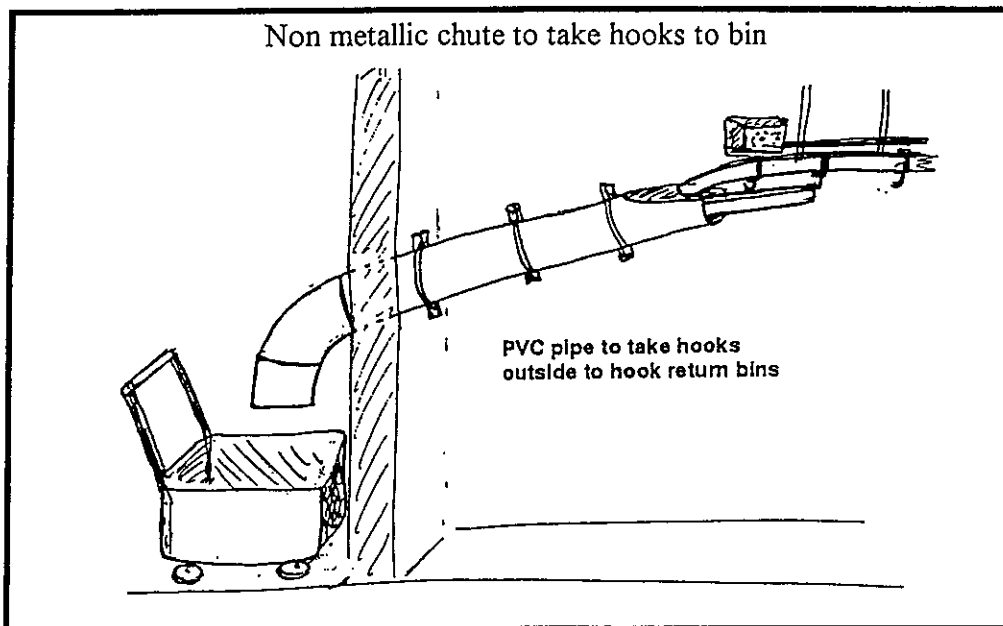

MRC - O, H & S BEST PRACTICE PROJECT
NOISE CONTROL OPTIONS No: N16

AREA:

Boning

NOISE SOURCE:

Air-conditioning outlets

- smaller outlets create high speed noise.
- transmission of air-conditioning noise along metal ducts.

CONTROL OPTIONS:

1. Use larger outlets
2. Use alternative dispersion devices eg. air-conditioning socks.
3. Lower fan speeds to reduce noise generation (see No 03).
4. Fit sound attenuators to duct work.

Picture of aircon sock.

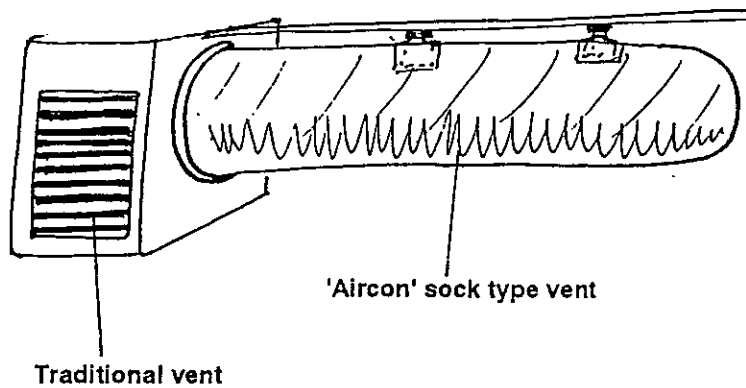

MRC - O, H & S BEST PRACTICE PROJECT
NOISE CONTROL OPTIONS No: N17

AREA:

Production areas -

NOISE SOURCE:

Transmission of engine noise through flooring and connected equipment.

CONTROL OPTIONS:

1. Use buffers eg. polyurethane and spring mountings to isolate the engine from the supporting structure and decrease vibration transmission.
2. Ensure conveyors are not connected directly to hoppers of machine to reduce transmission tracks.

Various types of engine mounting isolators.

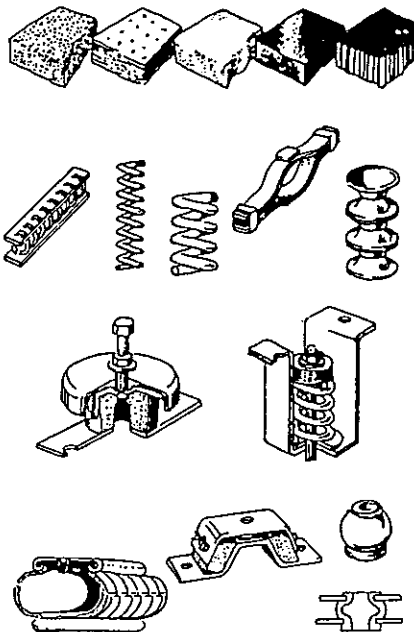

MRC - O, H & S BEST PRACTICE PROJECT
NOISE CONTROL OPTIONS No: N18

AREA:

Kill Floor / Production areas -

NOISE SOURCE:

Workers tapping on handrails with the backs of knives.

CONTROL OPTIONS:

Fill hollow sections with sand or cement

Picture of the handrail filled with sand.

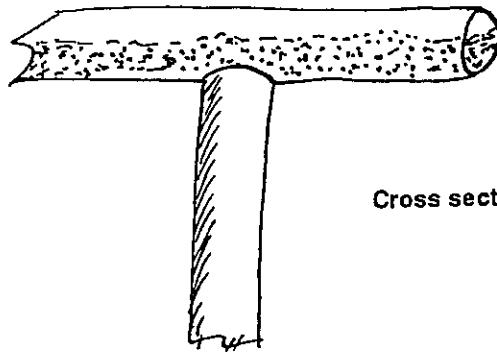

Cross section of handrail

MRC - O, H & S BEST PRACTICE PROJECT
NOISE CONTROL OPTIONS No: N19

AREA:

All areas

NOISE SOURCE:

Equipment noise

CONTROL OPTIONS:

1. Ensure all future equipment purchases have noise specification ratings below the recommended levels (ie below 80 dB (A)).
2. Ensure equipment is installed such that noise and vibration is isolated from work area.

P RINCIPLES OF NOISE CONTROL.

Every noise problem in an abattoir has three parts:

- a *source* - from which the noise originates and radiates (such as saws, metal contact, released compressed air, etc.)
- a *path* - along which the noise travels. (This could be either passage through the air or along an object such as a wall or pipe.)
- a *receiver* - the ears of the person hearing the noise.

Noise exposure may be controlled by:

1. Modifying the noise source to reduce the noise output, and or altering or blocking the transmission path of the noise to reduce the noise levels reaching the receiver. (*Engineering controls.*)
2. Removing or limiting the receiver from the area.
(*Administrative controls*)
3. Preventing the exposure of the receiver.
(*Personal protective equipment.*)

The use of Administrative controls and personal protective equipment to control noise exposure are practicable solutions in some circumstances, but are not considered in detail in this booklet. This is in line with the focus of the National Code of Practice for Noise Management, which challenges engineers, machinery designers, manufacturers and managers to control or eliminate the noise at the source. Hence administration controls, hearing protectors or earplugs should only be considered as temporary or last resort option once a noise problem is identified in your abattoir.

N OISE CONTROL PLANNING

Planning a noise control strategy should be done in consultation with employees and employee representatives. This should involve the development of a written noise control policy and program of action for implementing noise controls and managing exposure to noise. Copies of the policy and program of action should be available to all employees and their representatives on request, and form a basic part of the information, induction and training activities.

The noise control policy sets goals for the workplace in terms of noise exposure levels to be attained and the broad strategies to be used to minimize them. The policy should be reviewed at regular intervals and updated as necessary.

Typical policies should cover the following issues (where appropriate):

- goals for noise levels and peak noise levels for existing and new work areas .
- guidelines for the selection and purchase of quiet plant.
- noise controls to be used in temporary work areas.
- agreements with contractors
- audiometric testing and records
- funding allowances for noise control programs
- review dates for the program

(see Section 6.1, National code of Practice for Noise Management and Protection of Hearing at Work.)

Note that individual State and Territory legislation may set specific requirements in regard to noise control. The relevant documents should be consulted prior to developing a noise control policy and plan.

ENGINEERING CONTROLS

The most effective engineering methods for reducing workplace noise involves consideration of the total system, that is the noise sources, transmission pathways and receivers.

For most industrial noise problems there may be several sources which need to be tackled. It is necessary to establish the relative contribution each makes to the total noise generated.

When seeking an engineering solution to a noise problem, an understanding of the operation of the machinery or process is necessary to consider the possible treatment of the noise at the source. Engineering measures can be specifically targeted at the machinery, and its parts, or the total process.

ENGINEERING CONTROLS AT THE SOURCE.

Noise control solutions that may be applicable at the noise source include:

- **The purchase of new plant**, the design of the area in which it is to be installed and the design of new workplaces generally, provide an opportunity for cost effective noise control measures. All new plant and equipment should specify maximum noise emission data, and this should be a consideration in future purchases. Although many abattoirs rarely enjoy new plant opportunities, when these do arise, the issue of noise generation should be part of the design brief.

- **Eliminate or replace the plant** or its operation by a quieter operation, with equal or better efficiency, (eg, replace rivets with welds.) .
- Make minor design changes to **reduce specific noise sources**, eg. avoid metal to metal contact with the use of nylon or polyurethane bumpers, improved gearing etc.
- Correct the **specific machine elements** causing the noise by a local source approach, rather than by consideration of the entire machine as a noise source eg. by the addition of vibration isolating mountings, mufflers or silencers for air and gas flows, reduce air velocity of free jets etc.
- **Maintain plant** properly, by replacing worn bearing and gears, improving lubrication, tightening loose parts (especially guards) tension slapping belts, balance all rotating parts and prevent air or steam leaks.
- **Isolate** the vibrating machine parts to reduce noise from vibrating panels or guards.
- **Materials handling** processes, in particular, can be modified to ensure the impact and shock during handling and transport are minimized as far as possible. This may be achieved by;
 - Minimizing the fall height of items onto hard surfaces.
 - Fixing damping materials to, or , stiffening tables, panels or containers where they are struck by materials or items during processing.
 - Absorbing shock through the provision of wear resistant rubber or plastic coatings
 - Using conveyors instead of rollers, which are more likely to rattle
 - Controlling the speed to better match the production flow, thereby reducing the noise generation due to stop-start impact noise.

ENGINEERING CONTROLS OF THE NOISE TRANSMISSION PATH.

If it is not possible to change or modify the noise generation at the source, engineering solutions which interfere with the path of transmission between the source and the receiver should be investigated.

This may include:

1. **Isolating noise emitting equipment** away from the majority of the work population, the noisy elements that are not an integrated part of the basic plant, i.e. pumps, air compressors, fans, away from the general work areas.

2. **Isolating the noise source** or the employees in an acoustic enclosure.
 - Distance is often the cheapest solution (but it may not be effective in cases of excessive reverberation in the area ie with bone crushers.)
 - Use of full or partial partitions or barriers between the source and the receiver can be effective, especially with the use of absorbing material on the noise source side.
 - Walls and enclosures designed to limit noise should be constructed using sound absorbent as well as sound blocking elements. Sound absorbents, with the use of reinforcements and bracing in strategic areas will minimise resonance.

Materials which are good noise barriers are poor absorbers of sound, i.e. steel, brick, concrete, lead. The denser and heavier the material, the better the noise barrier. Access to enclosed machine elements must be by sealed doors or panels. Small holes or openings in enclosures can severely limit the reduction achieved.

- The use of traditional sound absorbing materials (ie. polyurethane foams, rockwool, fiberglass, carpet, etc.) are often not practical in the abattoir environments due to the difficulty of cleaning and contamination risk. New state-of-the-art materials and "skinned " materials are under investigation for their suitability to be used in these environments.

A system should be established to ensure regular inspection and maintenance of vibration mountings, impact absorbers, gaskets, seals, silencers, barrier, absorptive materials and other equipment used to control noise.

PRIORITIZING ENGINEERING BASED NOISE CONTROL EFFORTS

When considering which noise sources or in which area noise exposure should first be controlled by engineering means, the following factors should be considered:

- the magnitude of the noise ($L_{Aeq 8 hr}$) and the peak noise level.
- the number of exposed employees who will benefit from the control measures
- the practicability of the solutions within your abattoir.

APPENDICES

- a. Measuring Noise In Abattoirs**
- b. Administrative Controls**
- c. Personal Protective Equipment**
- d. How We Hear**
- e. Definitions**
- f. Useful contacts**
- g. Useful References**

APPENDIX a

MEASURING NOISE IN ABATTOIRS

Some key considerations in planning a noise measuring program include:-

- Assessments are undertaken in order to:
 - quantify the amount of noise to which employees are exposed and hence their risk of hearing loss.
 - help identify sources of noise and control strategies.
- The assessment should generally be undertaken during an employees representative workday, with the microphone of the sound measuring equipment as close as possible to the persons ear(s) in the normal working position.
- Noise measurements and exposure assessment should be undertaken in accordance with AS1269 Section 2.

(Note: the instruments selected will depend upon the circumstances and the purpose of the assessment. All sound level meters should comply with the specifications handed down in AS1259 and noise dosimeters should comply with AS2399).

- AS1269 describes two stages in carrying out a noise assessment and a detailed assessment.

A preliminary assessment should be undertaken to obtain an indication as to whether an employees noise exposure may exceed the exposure standard. Instances where the preliminary assessment may indicate excessive exposure signal the need for a more detailed assessment.

The detailed assessment should produce results in the form of $L_{Aeq\ 8\ hr}$ and peak noise level for each employee likely to be exposed.

- The assessment should be undertaken by a competent person with the necessary education and experience in interpreting the results obtained.

APPENDIX b

ADMINISTRATIVE CONTROLS

Administrative controls are modifications to the system of work to reduce either the duration of exposure or the magnitude of exposure. (This is sometimes possible with high frequency noise as it is directional and task redesign may be used to reduce exposure).

Other examples of administrative controls include:

- organizing schedules so that noisy work is done when as few employees as possible are present.
- planning to even out the work load and avoid busy times when machines are operating for longer hours.
- keeping employees out of noisy areas if their job does not require them to be there.
- job rotation, which is the rotation of employees out of noise affected areas for periods to reduce noise exposure.

APPENDIX c

PERSONAL PROTECTIVE EQUIPMENT. (PPE)



When engineering and administrative controls will not or are not practicable to reduce the exposure to noise below the National Standard for Occupational Noise, employees should be supplied with and wear, effective personal hearing protectors. They should only be considered to be an interim measure while engineering control of noise exposure is being achieved. All areas that may expose persons to excessive noise should clearly marked (with the boundaries noted) and signposted accordingly. This includes areas, machinery and tools. Using this standard hearing protection warning symbol (from AS1319.)

The function of hearing protection devices is to reduce the amount of noise reaching the inner ear of the wearer. This is achieved by completely covering the ear with an earmuff or helmet, by covering the entrance of the ear canal with a cap, or by completely occluding the canal with an ear plug.

The removal of hearing protection even for short periods of time can significantly reduce its effectiveness and can lead to the exposure standards being exceeded. Due to the difficulty of wearing hearing protectors for long periods of time in certain environments, regular brief periods in quiet areas without hearing protection should be provided. These quiet areas should have levels of less than 80 dB (A) to be effective.

Selection of Personal Hearing Protectors.

It is important to ensure that the protectors will provide wearers with reliable and adequate protection as well as giving them a choice of the type of protector they prefer.

Suppliers are required to give a range of information to enable you to choose the appropriate type. (All should conform with Australian Standard AS 1270 in both specification and testing) This should include information of the sound reducing capacities, the methods used to test the protectors and the details of the laboratories carrying out the tests. These should be made available to employers, employees and their representatives.

Basic information on Personal Protective equipment.

PLUGS VS MUFFS

There are many types of earplugs and muffs on the market. When determining the most suitable type the following points need to be taken into consideration:

- degree of protection required.
- suitability of use in that environment.
- comfort, weight and clamp force of the protector.
- the fit to the user
- the safety to the user and fellow employees.

In general, plugs have the advantage that they gain the best wearer compliance, but have the disadvantage that they are more difficult to maintain appropriate hygiene standards, (see below on different types) and can be difficult to fit correctly.

Muffs however are easy to fit in dirty and adverse conditions and can be cleaned. However compliance in wearing muffs can be difficult; particularly when other PPE is required, ie glasses.

The following information is on the different classes of ear plugs available

TYPES	ADVANTAGES	DISADVANTAGES
<u>Disposable</u> (Pre moulded) made of plastic or rubber and available in a number of sizes	Cheap Can be cleaned	Do not fit well
<u>Disposable</u> Made of fibre glass wool		Cannot be reused so are expensive Has the highest rate of infection
<u>Disposable</u> (Semi - reusable) Made from sponge plastic (When squashed they slowly expand back to fill the ear canal)	Provide good fit and attenuation	Cannot be cleaned
<u>Reusable.</u> Made from silicone rubber or acrylic, from an ear impression	Very good fit and attenuation Can be cleaned	Expensive to make

COMMUNICATION OVER HEARING PROTECTION

In persons with normal hearing Personal Protective Equipment (PPE) does not reduce their ability to hear speech over the operation of machines. This is because we normally raise our voices to louder than the surrounding noise. The ear can hear the loudest of the two sounds.

A protective device reduces the background noise as well as the voice to the same amount. If it can be heard without hearing protection, it can be heard with the protective devices on. Exceptions to this are when the wearer is deaf, or if there is overprotection. Also the sense of sound direction may be affected with the use of hearing protection. To prevent overprotection use the SLC₈₀ method of selection of the protection, aiming at dB(A) level under the device of about 80 dB(A) (see AS1270 for a description of the SLC method). If the person is already deaf, slightly reduce the protection. Note however it is better to slightly underprotect than overprotect, as with overprotection, the wearer will be inclined not to wear it. Maximum protection available from muffs and plugs is around 35 dB(A) due to bone conduction of the noise.

The use of secondary protective devices ie muffs over plugs only marginally increases the protection.

APPENDIX d

HOW WE HEAR.

The human ear consists of three parts, the outer ear, middle ear and the inner ear. The outer ear consists of the pinna ("ear") and the auditory canal. Airborne soundwaves enter the ear via these structures and vibrate the ear drum, which is the interface between the outer ear and the middle ear. The middle ear acts as the impedance matching device and has three small bones which act as a set of levers.

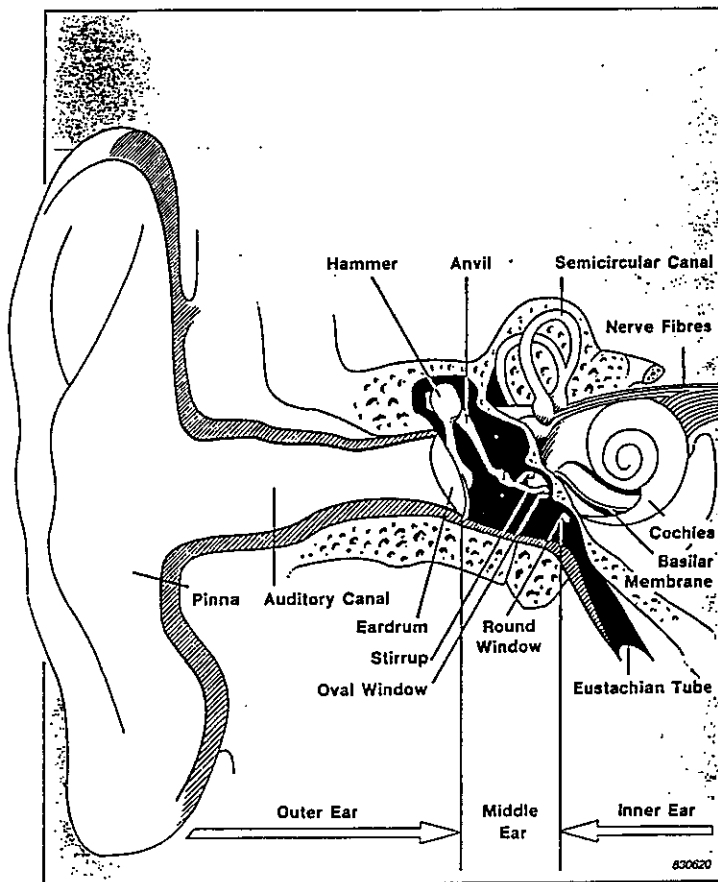

These bones, called the hammer, anvil and stirrup, transmit the vibrations from the ear drum to the inner ear. The inner ear consists of two separate systems, the semi-circular canals which are balance mechanisms and the cochlea, which is a fluid filled snail shaped tube which is divided longitudinally into 2 parts by the basilar membrane. Sound, transmitted to the cochlea, via the ear drum and the three bones, disturbs the fluid in the cochlea, and distorts the basilar membrane. On the surface of the basilar membrane are thousands of very sensitive hair cells. The hair cells register this distortion and transform them into nerve impulses which are then transmitted to the brain, and interpreted as sound.

Prolonged exposure to loud sounds causes damage to the hair cells with the result of progressively impairing the hearing ability. At first the damage is to a few hair cells with no perceivable difference in hearing. As more of the hair cells become damaged, the brain is unable to make up for the difference and the hearing is impaired. This often results in words running together, speech and back ground information cannot be distinguished and music becomes muffled.

Considerable and permanent damage has been sustained by the time that the listener becomes aware of the loss.

Loss of hearing can occur by a number of methods, but in industry noise induced hearing loss (NIHL) or noise induced permanent threshold shift is the most common problem. Typically prolonged exposure to noise above 85 dB(A) will cause NIHL. The hearing loss is normally greatest at the those frequencies where the ear is most sensitive, ie around the 4000 Hz (4kHz.) Loss is usually greater in the earlier years, however the loss in the later years generally has more effect on lower frequencies and has a worse effect on speech reception. Thus it is never too late to protect.

APPENDIX e

DEFINITIONS FROM NATIONAL THE CODE OF PRACTICE FOR NOISE MANAGEMENT AND PROTECTION OF HEARING AT WORK (NOHSC:2009(1993).)

The technical measurements and definitions used in assessing noise are set out in the National Code of Practice.

These include:-

- 'Acoustic' (or acoustical)** means containing, producing, arising from, actuated by, related to, or associated with, sound.
- 'Administrative noise control measures'** are work systems designed to substantially reduce noise exposure, including the time exposed to noise. Examples are job rotation, job redesign or rosters which are designed to reduce exposure to noise.
- 'Attenuation'** means a reduction in the magnitude of sound.
- 'A-weighting'** refers to a standardized frequency response used in sound measuring instruments. It corresponds approximately to the human ear response at low sound levels. Sound pressure levels measured using this response, which is specified in Australian Standard AS1259.1, are expressed in units of dB(A).
- 'C-weighting'** refers to a standardized frequency response used in sound measuring instruments. It corresponds approximately to the human ear response at high sound levels. Sound pressure levels measured using this response, which is specified in Australian Standard AS1259.1 are expressed in units of dB(C).
- 'Consultation'** means the sharing of information and exchange of views between employers, employees and/or employee representative(s) on health and safety issues. It includes the opportunity to contribute to decision making in a timely fashion to minimize the risk(s) of exposure to excessive noise.
- 'dB'** means the abbreviation for decibel. Also *see* definition for 'decibel'.
- 'dB(A)'** means A-weighted decibel. Also *see* definition for 'A-weighting.'
- 'dB(C)'** means C-weighted decibel. Also *see* definition for 'C-weighting'.
- 'dB(lin)'** means unweighted decibel. Also *see* definition for 'unweighted.'
- 'Decibel'** is the unit used to indicate the relative magnitude of sound pressure level and other acoustical quantities. The range of sound pressures commonly encountered is very large so a logarithmic scale is used. The decibel is the unit used on this scale and is abbreviated to 'dB'. On the decibel scale, the threshold of hearing occurs at a sound pressure level of about 0 dB and the threshold of pain occurs at about 120dB. As the decibel is also used to describe the level of other quantities, such as sound power and vibration acceleration, it is always necessary to refer to the specific quantity being measured, for example.

$L_{Aeq\ 8\ hr}$ OR $L_{peak\ (lin)}$

DEFINITIONS FROM NATIONAL THE CODE OF PRACTICE Contd.

- 'Employee'** means an individual who works under a contract of employment, apprenticeship or traineeship.
- 'Employee representative(s)'** includes an employee member of health and safety committee where established in the workplace, or a person elected to represent a group of employees on health and safety matters.
- 'Employer'** means a corporation or an individual who employs persons under contract of employment, apprenticeship or traineeship.
Note: The definition of employer includes the *self-employed* which means a person who works for gain, other than under a contract of employment, apprenticeship or traineeship, whether or not that person employs others.
- 'Engineering noise control measures'** means any engineering procedure that reduces the sound level either at the source of the noise or in its transmission, but does not include the use of administrative noise control measures or personal hearing protectors.
- 'Excessive noise'** means, for the purpose of this national code of practice, noise levels exceeding $L_{Aeq,8h}$, 85dB(A) or L_{peak} 140dB(lin), as defined in the *National Standard for Occupational Noise* [NOHSC:1007 (1993)]. During normal operations, no employee may enter such an area without wearing appropriate personal hearing protectors. Hearing protection areas should be clearly defined and sign-posted according to Australian Standard AS1319
- 'Impulse sound'(or noise)** means sound consisting of a single pressure peak, or a sequence of such peaks, or a single burst with multiple pressure peaks whose amplitude decays with time, or a sequence of such bursts.
- ' $L_{Aeq,8hr}$ '** (eight hour equivalent continuous A-weighted sound pressure level in dB(A) referenced to 20 micropascals) means that steady noise level which would, in the course of an eight-hour period, cause the same A-weighted sound energy as that due to the actual noise over an actual working day. $L_{Aeq,8h}$ is to be determined in accordance with the Australian Standard AS 1269.
- ' L_{peak} ' (peak noise level)** means linear (unweighted) peak sound pressure level in decibels referenced to 20 micropascals and measured by a sound level meter with a peak detector-indicator characteristic complying with Australian Standard AS1259.
- 'Noise'** means any unwanted or damaging sound.
- 'Noise control policy'** means a written policy, developed by the employer, in consultation with employees and employee representative(s) which sets goals for noise exposure levels in the workplace and the strategies to be used to meet these goals.
- 'Noise exposure'** means the amount of sound energy the unprotected ear of a person is exposed to, given as $L_{Aeq,8h}$ or as L_{peak} .

DEFINITIONS FROM NATIONAL THE CODE OF PRACTICE Contd.

- ‘Occupational noise-induced hearing loss’** means hearing impairment arising from exposure to excessive noise at work. Occupational noise-induced hearing loss is also commonly known as industrial deafness.
- ‘Peak noise level’** *see* definition for L peak.
- ‘Personal Protection Equipment’** means devices worn by the user to isolate the entry of noise into their ears.
- ‘Personal Protection program’** means a program for personal hearing protection, and where required, regular hearing testing, which is adopted where technical or economic problems delay, or make impracticable, the reduction of exposure to excessive noise by engineering or administrative noise control measures.
- ‘Plant’** means any machinery, equipment, appliance, implement or tool, and anything fitted or connected to them.
- ‘Practicable’** means ‘practicable’ in Victoria, Queensland, Western Australia and the Northern Territory, ‘reasonably practicable’ in New South Wales, South Australia, the Australian Capital Territory and Commonwealth jurisdiction, and a ‘reasonable precaution’ in Tasmania.
- ‘Reverberation’** means the persistence, by echo or reflection, of sound in an enclosure after the emission by the source has stopped.
- ‘Risk’** means the probability of harm occurring to the hearing of a person.
- ‘Shall’** means that a requirement is mandatory.
- ‘Sound’** means small fluctuations in the air pressure that result in a wave capable of exciting in a listener the sensation of hearing.
- ‘Tinnitus’** means ringing or other noises in the head or ears which can be caused by exposure to excessive noise. Tinnitus can become permanent and when severe may disrupt sleep, reduce concentration and lead to irritability and depression. Tinnitus may lead to increased absenteeism and decreased productivity. It can also affect general job satisfaction and contribute to adverse health effects, such as, stress.
- ‘Unweighted’** means sound pressure levels or similar quantities that are measured using an instrument that responds equally to all frequencies, that is, it has a flat or linear frequency response. Sound pressure levels measured using this response are expressed in units of dB(lin).
- ‘Workplace’** means any place, including any aircraft, ship or vehicle where an employee works, or is likely to work, and includes any place where an employee goes while at work.

APPENDIX f

USEFUL CONTACTS:

List of some useful Industry contacts / Associations

- (1) Association of Noise Control Engineering Inc.
PO Box 484
Mount Eliza, Victoria 3930

- (2) Australian Acoustical Society.
653 Mountain Highway
Bayswater, Victoria 3153

- (3) Association of Australian Acoustical Consultants.
Secretary
Athol Day
Day Design Pty Ltd
776 Forest Road
PEAKHURST NSW 2210

APPENDIX G

USEFUL LITERATURE AND REFERENCE DOCUMENTS

1. Standards Australia

- Standards Australia, AS1259.1 Acoustics-Sound Level Meters, Part 1: Non-integrating, Standards Australia, Sydney.
- Standards Australia, AS1259.2 Acoustics-Sound Level Meters.
- Standards Australia, AS1319 Safety Signs for the Occupational Environment, Standards Australia, Sydney.
- Standards Australia. AS1269 Acoustics-Hearing Conservation, Standards Australia, Sydney.
- Standards Australia, AS1270 Acoustics-Hearing Protectors, Standards Australia, Sydney.
- Standards Australia, AS2659 Guide to the Use of Sound Measuring Equipment, Standards Australia, Sydney.
- Standards Australia, AS2399 Personal Noise Dosemeters, Standards Australia, Sydney.

2. National Acoustics Laboratories

- * Attenuation of Hearing Protectors (current criteria)
- * Criteria for Assessing Hearing Conservation Audiograms.

3. Worksafe Australia

Occupational Noise: National Standard and National Code of Practice (1993).

Strategy 1989: National Strategy for the prevention of occupational noise induced hearing loss (1989).

4. Victorian Occupational Health and Safety Authority
SHARE Solutions.

- N1 Reduce speed = reduce noise.
- N4 Damping contact surfaces.
- N5 Absorption lining of guard produced cheap noise reduction.
- N20 Reducing noise from compressed air blow-off jets.
- N25 Noise reduction achieved by dampening conveyor or chute for manufactured components.
- N32 Noise control for elevators by acoustic enclosures.
- N34 Noise reduction of pneumatic scrap handling process.
- N45 Noise reduction of steam line regulators.
- N48 Noise reduction treatment of a fork lift truck.
- N51 Hammering noise reduced by ceiling baffles.
- N52 Table surface quietens noise bottles.
- N61 Reducing noise levels by modifying the saw blade.